

Cabinets & Enclosures

ACCESSORIES FOR 19" CABINETS

Lighting Module:

- 11 watt 220 volts 50 Hz with switch and european standard outlet (UTE standard).
- Supplied with a cord. Magnetic fixing on any steel part at any position

Power Bar:

- 19" x 1 HU
- 6 outlets (2 + T) + 1 automatic circuit breaker 16 Amps 220 V
- nominal voltage 250 V 50 Hz
- cord : 2 m
- German plug, according to Schuko Standard



19" Shelf:

- polyester powder paint coated steel, colour RAL 9002
- 2 fixation points on the front uprights with M 6 X 12 bolts and cage nuts M6
- dimensions: 19" x 3 HU x 405 mm (H x W x D)
- maximum load : 70 kg

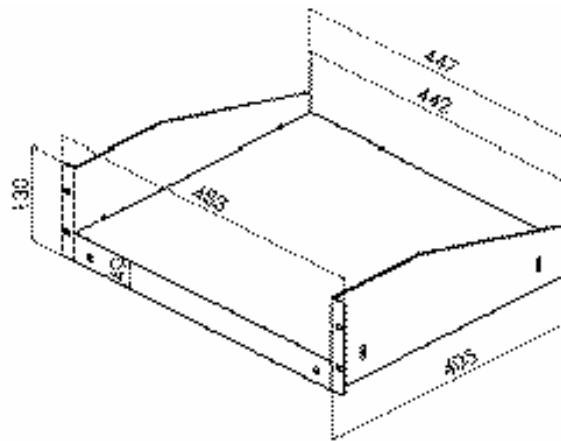

19" Shelf - Galvanized steel:

- 4 fixation points (on the 4 uprights) with M6 X 12 bolts and cage nuts M6
- dimensions: 1 HU x 483 x 531 (H x W x D)
- maximum load : 70 kg

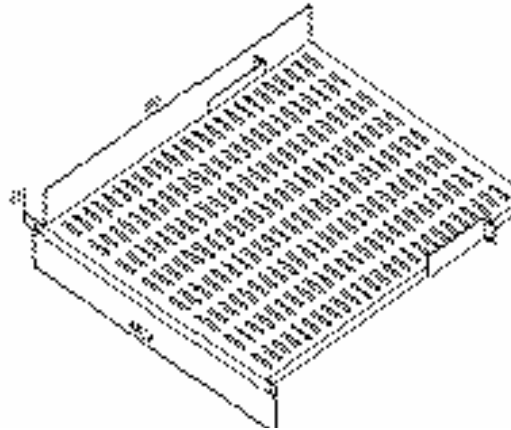

19" Sliding shelf:

- can be pulled out of the frame
- galvanized steel 1,5mm
- max. load : 20 kg

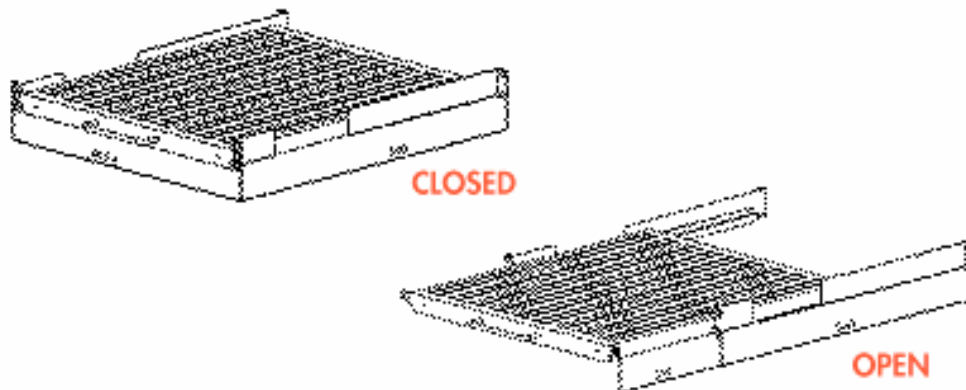

19" Cable Fixingplate:

- for use on the back frame of the cabinet
- fixed with 4 cage-nuts and bolts M6
- zinc plated steel (White)

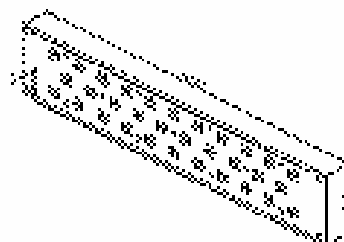

Adjustable Feet:

- included in standard QM II
- for bottom of cabinet and pedestal
- M10 x 52 Diam. Foot = 30

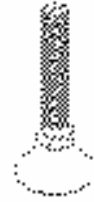

Pedestal 800 x 800 for Quick Mount 100 mm:

- used to place under an entire quick-mount cabinet
- attached to the quick-mount cabinet 's base by 4 x M8 bolts, from inside the cabinet
- provides extra cable-entrances
- polyester powder paint coated steel, color RAL7012

8 x Patchring:

- 8 fixed on side of both front uprights to allow neat cabling
- patch rings have 2 compartments (easy for winding up overlength of patch cords)



Ventilator:

- 8 fans maxi (see drawing) can be fixed on the roof
- air flow : per fan 160 m³ /h
- dimensions 119 x 119 thickness : 38 mm
- 220 V 50HZ
- noise level 46 Db
- service life : 27500 hours (approval CSA, UL,VDE)
- 2 finger guards (grid on top and bottom)
- 1 power wire 3 x 0.5 mm 2 equipped with UTE moulded plug and terminal connectors
- 1 cable grip
- 4 MA-50 CBL screws + 4 nuts
- 1 earth screw

